

**TRITON**

## Safeguard Pumped Care electric shower

### ! IMPORTANT !

Under **\*NO** circumstances must this shower be connected directly to a mains water supply.

It is designed for **GRAVITY FED COLD WATER** systems **ONLY** !

\* Failure to comply may invalidate product warranty

## Installation and User instructions

INSTALLERS PLEASE NOTE THESE INSTRUCTIONS ARE  
TO BE LEFT WITH THE USER

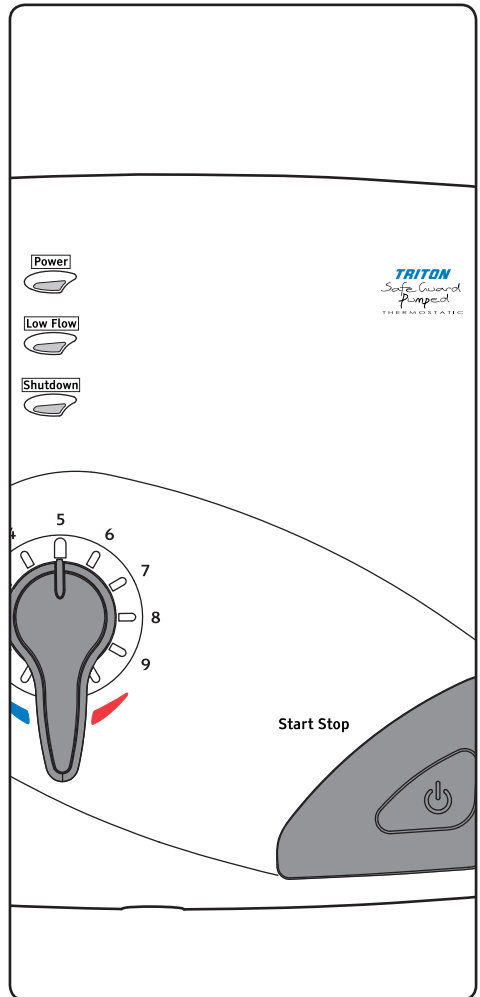

### IMPORTANT SAFETY ADVICE

- The shower unit **MUST BE** switched off at the isolating switch when not in use. This is a safety procedure recommended for all electrical appliances.
- The showerhead and hose supplied with this product are a safety critical part of your shower. Failure to use genuine Triton parts may cause injury and invalidate your guarantee.



## **PLEASE READ THIS IMPORTANT SAFETY INFORMATION**

Products manufactured by Triton are safe and without risk provided they are installed, used and maintained in good working order in accordance with our instructions and recommendations.

- ⚠ WARNING: DO NOT** operate shower if frozen, or suspected of being frozen. It must thaw out before using.
- ⚠ DO NOT** operate the unit if the showerhead or spray hose becomes damaged.
- ⚠ DO NOT** restrict flow out of shower by placing showerhead in direct contact with your body.
- ⚠ DO NOT** operate the shower if water ceases to flow during use or if water has entered inside the unit because of an incorrectly fitted cover.
- ⚠ WARNING: If restarting the shower immediately after stopping, be aware that a slug of hot water will be expelled for the first few seconds.**
- ⚠** The spray head must be descaled regularly.
- ⚠** Fit only shower heads recommended by the manufacturer and never fit any additional device to restrict the water outlet flow.
- ⚠** The outlet must not be connected to any tap or fitting other than those specified.
- ⚠** This appliance must not be connected to the water mains supply and not connected by a hose set.
- ⚠** A suitable double pole isolation switch for supply disconnections must be incorporated in the fixed wiring circuit in accordance with current wiring rules. See Electrical Installation section for further details.

Minimum inlet pressure 0.08 metres 0.78kPa  
Maximum inlet pressure 10 metres 100kPa (1 bar)

**This book contains all the necessary fitting and operating instructions for your electric shower.**  
**Care taken during the installation will provide a long, trouble-free life from your shower.**

### **⚠ WARNING ⚠**

This appliance can be used by children aged from 3 years and above and persons with reduced physical, sensory or mental capabilities or lack of experience and knowledge if they have been given supervision or instruction concerning use of the appliance in a safe way and understand the hazards involved. Children may not play with the appliance. Cleaning and user maintenance shall not be made by children.



## IMPORTANT - PLEASE READ THESE GENERAL GUIDANCE NOTES BEFORE PROCEEDING



### 1 GENERAL

- 1.1 Isolate the electrical and water supplies before removing the cover.
- 1.2 Read all of these instructions and retain them for later use.
- 1.3 **DO NOT** take risks with plumbing or electrical equipment.
- 1.4 Isolate electrical and water supplies before proceeding with the installation.
- 1.5 The unit must be mounted onto the finished wall surface (on top of the tiles). **DO NOT** tile up to or seal around **ANY PART** of the unit using silicone sealer after fixing to the wall. Special care must be taken **NOT TO BLOCK OR SEAL ANY PRD VENTS ON THE UNIT**.
- 1.6 Contact Customer Service (*see back page*), if any of the following occur:
  - a) *If it is intended to operate the shower at pressures above the maximum or below the minimum stated.*
  - b) *If the unit shows a distinct change in performance.*
  - c) *If the shower is frozen.*
- 1.7 If it is intended to operate the shower in areas of hard water (above 200 ppm temporary hardness), a scale inhibitor may have to be fitted. For advice on the Scale Inhibitor, contact Customer Service.
- 1.8 The showerhead must be cleaned regularly with descalent to remove scale and debris, otherwise restrictions to the flow on the outlet of the unit will result in higher temperatures and could also cause the (PRD) Pressure Relief Device in the unit to operate.
- 1.9 This product is not suitable for mounting into steam rooms or steam cubicles.

### 2 PLUMBING

- 2.1 The plumbing installation must comply with Water Regulations, Building Regulations or any particular regulations as specified by Local Water Company or Water Undertakers and should be in accordance with BS EN 806.
- 2.2 The supply pipe must be flushed to clear debris before connecting to the shower unit.

- 2.3 **DO NOT** solder pipes or fittings within 300mm of the shower unit, as heat can transfer along the pipework and damage components.
- 2.4 **DO NOT** fit any form of outlet flow control as the outlet acts as a vent for the heater can.
- 2.5 **DO NOT** use excessive force when making connections to the flexible hose or showerhead, finger tight is sufficient.
- 2.6 All plumbing connections must be completed before making the electrical connections.
- 2.7 This appliance **MUST NOT** be connected to the inlet supply by a hose-set.

### 3 ELECTRICAL

- 3.1 The installation must comply with BS 7671 'Requirements for electrical installations' (IEE wiring regulations), building regulations or any particular regulations as specified by the local Electrical Supply Company.
- 3.2 This appliance **MUST** be earthed.
- 3.3 In accordance with 'The Plugs and Sockets etc. (Safety) Regulations 1994', this appliance is intended to be permanently connected to the fixed wiring of the electrical mains system.
- 3.4 Make sure all electrical connections are tight to prevent overheating.
- 3.5 A 30mA residual current device (RCD) **MUST** be installed in all UK electric and pumped shower circuits. This may be part of the consumer unit or a separate unit.
- 3.6 Switch off immediately at isolating switch if water ceases to flow during use.
- 3.7 Other electrical equipment i.e. extractor fans, pumps must not be connected to the circuits within the unit.

**3.8** Switch off at isolating switch when not in use. This is a safety procedure recommended with all electrical appliances.

- 3.9 As with all electrical appliances it is recommended to have the shower and installation checked at least every two years by a competent electrician to ensure there is no deterioration due to age and usage.

Contents	Page
IMPORTANT SAFETY INFORMATION AND GUIDANCE NOTES.....	2 - 3
<b>How to operate the shower .....</b>	<b>5 - 8</b>
Introduction .....	9
Specifications.....	9
Advice to users .....	9
Main components .....	10 - 11
Electrical requirements.....	12 - 13
Water requirements .....	14
Siting of the shower.....	15
Fitting the shower to the wall .....	16
Plumbing connections .....	17 -18
Electrical connections .....	19
Shower drain pumps (not supplied).....	20
Compatible shower drain pumps.....	21
Commissioning.....	22
<b>Adjusting the Maximum temperature stop</b>	
35°C to 47°C - Standard showering .....	23
<b>BEAB Care (41°C) .....</b>	<b>24</b>
PCB Dip Switch settings.....	25
Fitting the cover .....	26
Operating functions.....	27
Instructions for installers and service engineers only.....	28
Spare parts .....	29 - 30
Fault finding .....	31 - 32
In-service Testing .....	33 - 37
Water and Cable entry points .....	38
UK Service policy /Guarantee, etc. ....	rear cover

To check the product suitability for commercial and multiple installations, please contact Triton's specification advisory service before installation. Please see back of book for contact information.

# How to operate the shower

When the electricity supply to the shower is switched on at the isolating switch, the power indicator will light.

## To start the shower

Press the **start/stop** bar and water will flow. After a few seconds a flow of heated water will be available.

## To stop the shower (manually)

The shower can be stopped by pressing the **start/stop** bar. When pressed, the phased shutdown will begin and water will cease to flow after a few seconds.

## To stop the shower (timed Shutdown)

Shutdown times can be set at **5, 10, 20** (factory setting) or **30** minutes. When the indicator illuminates it indicates there is **1** minute before the timed shutdown will turn the shower off.

Fig.A

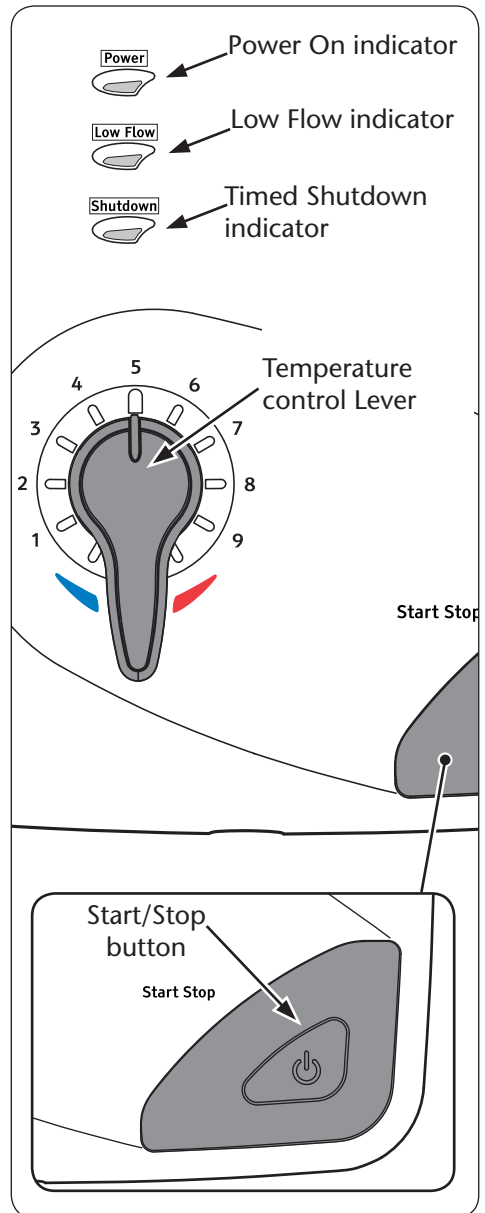

## Warning!

This appliance can be used by children aged from 8 years and above and persons with reduced physical, sensory or mental capabilities or lack of experience or knowledge if they have been given supervision or instruction concerning use of the appliance in a safe way and understand the hazards involved. Children may not play with the appliance. Cleaning and user maintenance shall not be made by children without supervision.

Fig.B

Approximately setting 5 as the maximum.

**DO NOT FORCE THE LEVER ANY FURTHER ONCE RESISTANCE IS FELT.**

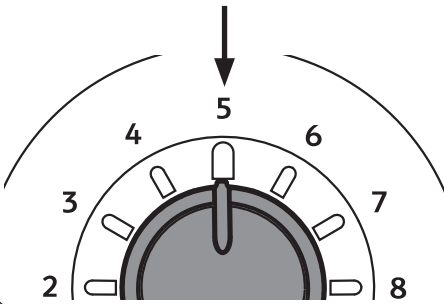

## To adjust the shower temperature

The water temperature is altered by changing the amount of **Hot** water from the heater can that is mixed with **Cold** water from the inlet. This is done by moving the temperature control lever (**Fig.A**).

Adjusting the temperature control can alter the flow of water through the unit.

After obtaining your preferred showering temperature the number setting can be remembered and left as the preferred setting.

**Important: When set to 41°C (BEAB Care setting) the temperature lever will sit at setting 5 (approximately) as its maximum position (Fig.B).**

## To decrease the shower temperature

Turn the temperature control **anti-clockwise**; this will increase the flow of water through the shower and is indicated by lower numbers.

## To increase the shower temperature

Turn the temperature control **clockwise**; this will decrease the flow of water through the shower and is indicated by higher numbers.

When the **start/stop** bar is pressed water will continue to flow in order to remove heated water inside the unit (see **phased shutdown process, page 25**). Water will cease to flow after a few seconds.

After phased shutdown the unit must be isolated via the 45amp-isolating switch.

## IMPORTANT

The shower unit **MUST BE** switched off at the isolating switch when not in use. This is a safety procedure recommended for all electrical appliances.

**Warning!**

Before normal operation of the shower, it is essential the commissioning procedure is completed correctly.

**Note:** It is advisable to be certain that the showering temperature is satisfactory by testing with your hand before stepping under the showerhead. There will always be a time delay of a few seconds between selecting a flow rate and the water reaching the stable temperature for that flow rate.

## Introduction

This book contains all the necessary fitting and operating instructions for your Triton electric shower.

Take time to read this book thoroughly and familiarise yourself with all instructions before commencing installation. Please keep it for future reference.

The shower installation must be carried out by a suitably qualified person and in the sequence of this instruction book.

Care taken during the installation will provide a long, trouble-free life from your shower.

## Specifications

### Electrical

rating at 230V

8.5kW – (40A MCB rating)

Pump motor rating 120 Watt – single phase.

### Water

Inlet connection – 15mm diameter.

Outlet connection – ½" BSP male thread.

### Entry Points

Water – **Right:** top, middle back, bottom.

Cable – **Right:** top, top back, bottom.

### Materials

Backplate, cover, controls, showerhead – ABS.

Sprayplate – Acetal.

Elements – Minerally insulated corrosion resistant metal sheathing.

### Dimensions

Height – 300mm

Width – 316mm

Depth – 90mm

### Standards and Approvals

Splashproof rating IPX4.

Complies with the requirements of current British and European safety standards for household and similar electrical appliances.

Complies with requirements of the British Electrotechnical Approvals Board (BEAB) and BEAB CARE mark (BEAB).

Meets with Compliance with European Community Directives (CE).

## Advice to Users

**Important:** When first installed the unit will be empty. It is essential the unit should contain water before the elements are switched on. It is vital that the commissioning procedure is followed. Failure to carry out this operation will result in damage to the unit and will invalidate the guarantee.

The following points will help you understand how the shower operates:

### a) Temperature/flow rate

The temperature control can be adjusted to provide shower temperatures between 35°C and 47°C.

Alternatively, adjusting the temperature stop mechanism inside the unit to 38°C, 41°C or 43°C maximum can restrict the shower temperature.

**Important:** To comply with BEAB care mark requirements (use in healthcare or special needs environment) the **Safeguard unit MUST be altered to 41°C**. The unit is factory set at 47°C (see page 22 on how to adjust the MAXIMUM temperature stop to 41°C, to meet BEAB care requirements).

At a selected showering temperature the unit will provide the optimum flow rate possible. Note the maximum flow rate for the given temperature will be greater in the summer than in the winter because of the variance in the ambient water supply.

Should water pressure/flow to the shower be insufficient for optimum performance then the unit will operate at a reduced power level and provide the highest flow rate possible for the given shower temperature.

### b) Temperature stabilisation

The shower will maintain temperature in accordance with the BEAB care mark.

**If ever the water becomes too hot, and you cannot obtain cooler water, first check that the sprayplate in the showerhead has not become blocked.**

DO NOT place items such as soap or shampoo bottles on top of the unit. Liquid could seep through the joint between the cover and backplate, and possibly damage the sealing rubber.

**This product is rated at:  
30 minutes on / 30 minutes off.**

# Main Components

Inside the unit (Fig.1)

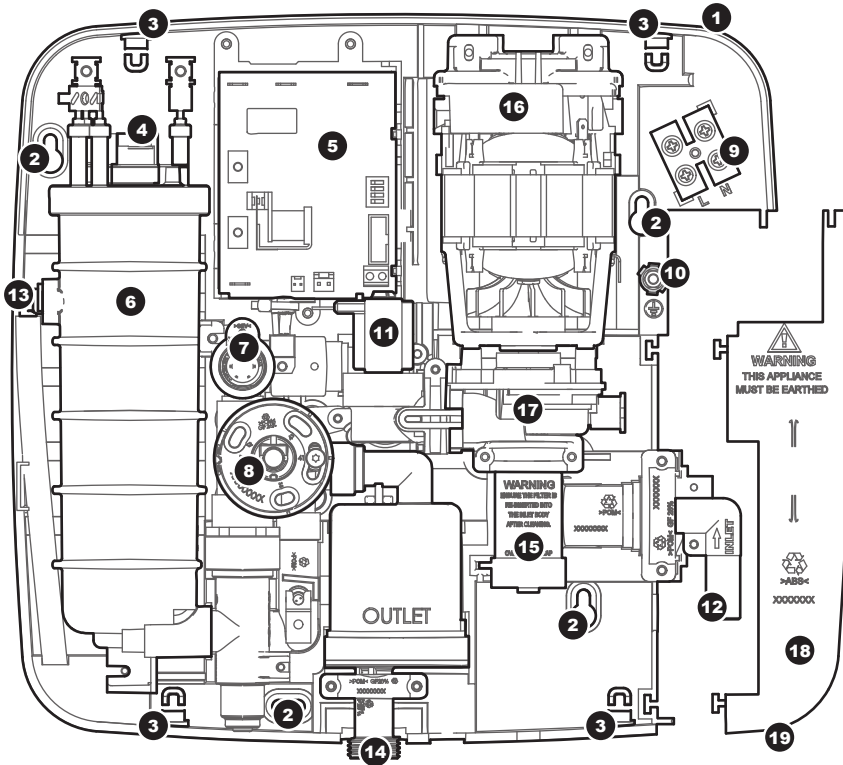

**Note:** Wires have not been shown for reasons of clarity.

Inside the unit (Fig.1)

- |                                |                                  |                             |
|--------------------------------|----------------------------------|-----------------------------|
| 1. Top cable/pipe entry        | 8. Temperature Control           | 14. Shower outlet           |
| 2. Wall screw fixings          | 9. Terminal block                | 15. Filter                  |
| 3. Cover screw fixings         | 10. Earth connection             | 16. Pump motor              |
| 4. Thermal safety cut-out      | 11. Solenoid valve               | 17. Pump                    |
| 5. Power printed circuit board | 12. Water inlet                  | 18. Trimplate               |
| 6. Can and element assembly    | 13. Pressure relief device (PRD) | 19. Bottom cable/pipe entry |
| 7. Flow switch assembly        |                                  |                             |

## Main Components (continued)

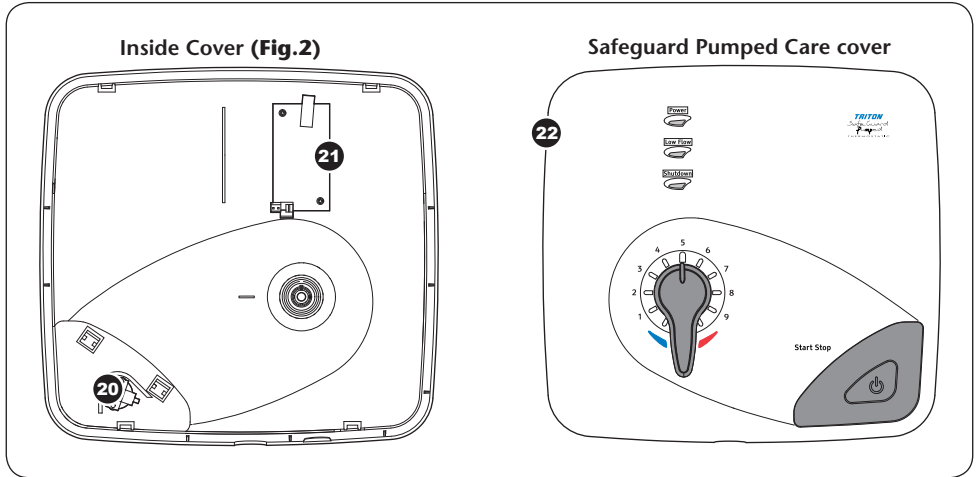

### Inside Cover (Fig.2)

- 20. Stop/start switch - Inside
- 21. Control printed circuit board - Inside

### 22. Front cover - Safeguard Pumped Care

#### Other items

- Instructions, guarantee, etc.

## Electrical Requirements

### Warning!

**This appliance must be earthed**

The installation, supply cable and circuit protection must conform with BS 7671 (IEE wiring regulations) and be sufficient for the amperage required.

### The following notes are for guidance only:

- 1** The shower must only be connected to a 230-240V ac supply. If you are installing a shower with a kilowatt rating above 9kW, it is advisable to contact the local electricity supply company.
- 1.1** The electrical rating of the shower is shown on the rating label (**Fig.3**) within the unit.
- 2** Before making any sort of electrical connection within the installation make sure that no terminal is live. If in any doubt, switch off the whole installation at the mains supply and remove the correct fuse.
- 3** The shower must be connected to its own independent electrical circuit. **IT MUST NOT** be connected to a ring main, spur, socket outlet, lighting circuit or cooker circuit.
- 3.1** The electrical supply must be adequate for the loading of the unit and existing circuits.
- 4** Check your consumer unit (main fuse box) has a main switch rating of 80A or above and that it has a spare fuse way which will take the fuse or Miniature Circuit Breaker (MCB) necessary for the shower (**Fig.4**).
- 4.1** If your consumer unit has a rating below 80A or if there is no spare fuse way, then the installation will not be straightforward and may require a new consumer unit serving the house or just the shower.
- 4.2** You will need to contact the local electricity company. They will check the supply and carry out what is necessary.
- 5** For close circuit protection **DO NOT** use a rewirable fuse. Instead use a suitably rated Miniature Circuit Breaker (MCB) or cartridge fuse (**see Table A**).
- 5.1** A 30mA residual current device (RCD) **MUST** be installed in all UK electric and pumped shower circuits. This may be part of the consumer unit or a separate unit.

**Fig.3**

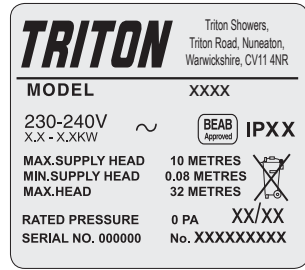

**Fig.4** Schematic of installation circuit

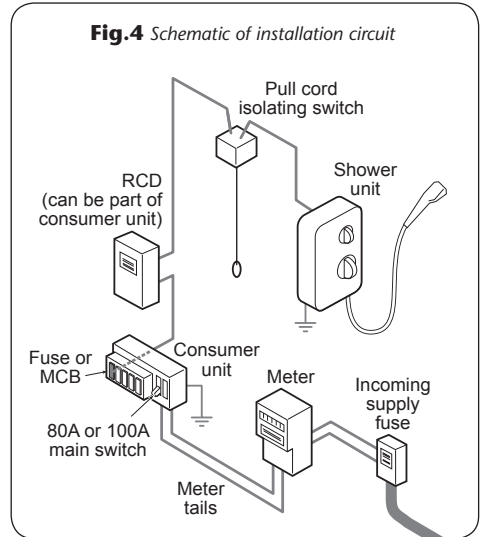

**Table A**

unit rating	CIRCUIT PROTECTION	
	MCB	cartridge fuse
7.0kW	30/32A	30A
7.5kW	32A	35A
8.0kW	40A	35A
8.5kW	40A	45A
9.0kW	40A	45A
9.5kW	40/45A	45A
10.5kW	45A	45A

- 6 A 45 amp double pole isolating switch with a minimum contact gap of 3 mm in both poles must be incorporated in the circuit.
- 6.1 It must have a mechanical indicator showing when the switch is in the OFF position, and the wiring must be connected to the switch without the use of a plug or socket outlet.
- 6.2 The switch must be accessible and clearly identifiable, but out of reach of a person using a fixed bath or shower, except for the cord of a cord operated switch, and should be placed so that it is not possible to touch the switch body while standing in a bath or shower cubicle. It should be readily accessible to switch off after using the shower.
- 7 Where shower cubicles are located in any rooms other than bathrooms, all socket outlets in those rooms must be protected by a 30mA RCD.
- 8 The current carrying capacity of the cable must be at least that of the shower circuit protection (**see Table B**).
- 8.1 To obtain full advantage of the power provided by the shower, use the shortest cable route possible from the consumer unit to the shower.
- 8.2 It is also necessary to satisfy the disconnection time and thermal constraints which means that for any given combination of current demand, voltage drop and cable size, there is a maximum permissible circuit length.
- 9 The shower circuit should be separated from other circuits by at least twice the diameter of the cable or conduit.
- 9.1 The current rating will be reduced if the cabling is bunched with others, surrounded by thermal loft or wall insulation or placed in areas where the ambient temperature is above 30°C. Under these conditions, derating factors apply and it is necessary to select a larger cable size.
- 9.2 In the majority of installations (**see Table B**), the cable will unavoidably be placed in one or more of the above conditions. This being so, it is strongly recommended to use a minimum of 10mm cabling throughout the shower installation.

- 9.3 In any event, it is essential that individual site conditions are assessed by a competent electrician in order to determine the correct cable size and permissible circuit length.

**Table B**

<b>Twin and earth PVC insulated cable Current carrying capacity</b>		
<b>Installed in an insulated wall</b>	<b>In conduit trunking</b>	<b>Clipped direct or buried in a non-insulated wall</b>
6mm <sup>2</sup> 32A	6mm <sup>2</sup> 38A	6mm <sup>2</sup> 46A
10mm <sup>2</sup> 43A	10mm <sup>2</sup> 52A	10mm <sup>2</sup> 63A
16mm <sup>2</sup> 57A	16mm <sup>2</sup> 69A	16mm <sup>2</sup> 85A

**Note:** Cable selection is dependent on derating factors

**\*The method below may be used by installers to determine the approximate size of the incoming cable.**

6mm<sup>2</sup>



10mm<sup>2</sup>



16mm<sup>2</sup>



1. Measure the width of an individual strand, and half that measurement to find (r),  
e.g:  $1.34\text{mm} \div 2 = (r) 0.67\text{mm}$
2. Multiply (r) x (r) x 3.14,  
e.g:  $(r) 0.67 \times (r) 0.67 \times 3.14 = 1.41\text{mm}^2$
3. Multiply this by the number of wire strands (usually 7), e.g:  $1.41\text{mm}^2 \times 7 = 9.87\text{mm}^2$ .
4. The number obtained would suggest 10mm<sup>2</sup> wiring.

**\*PLEASE NOTE:** If unsure, consult a qualified Electrician.

## Water Requirements

The installation must be in accordance with Water Regulations/Bylaws.

Supply Source.....	Gravity fed cold water only
Minimum Head.....	8cm
Maximum static pressure .....	100 kPa (1 bar) or (10m Head)
Maximum inlet temperature .....	28°C
Minimum inlet temperature .....	2°C

### Warning!

**Under no circumstances must this shower be connected directly to the mains water supply.**

To ensure activation of the heating elements, the shower must be connected to a cold water supply which is **Gravity Fed Only** from a static cold water storage cistern with a minimum capacity of 114 litres (25 gallons).

There must be a maximum head of water of 10 metres and a minimum head of 8 cm as measured between the bottom of the cistern and the top of the shower unit. There must be no other cold water draw-offs between the cistern and the unit and the pipe must not supply water to any other tap or fitting at a lower level.

**Note:** The supply pipe from the cistern should be on the opposite side to the float operated valve to prevent air being drawn into the pipe when the cistern is filling.

If it is intended to operate the shower in hard water areas (above 200 ppm temporary hardness) a scale inhibitor should be fitted.

**Fig.5** shows a typical system layout.

**DO NOT** use jointing compounds on any pipe fittings for the installation.

**Fig.5** Diagrammatic view (not to scale)

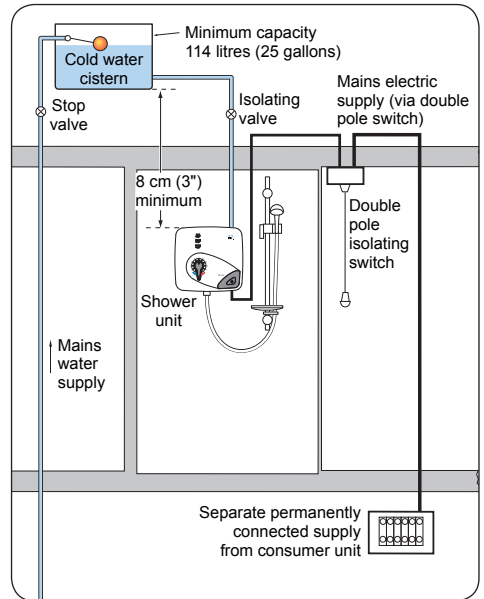

**Important: To comply with BEAB care mark in service testing procedure the isolating valve should be located close to the shower unit.**

## Siting of The Shower

For ease of servicing, the unit must always be mounted on the surface of tiled walls. Never tile up to the unit.

Refer to **Fig.6** for correct siting of shower. Position the unit where it will not be in direct contact with water from the showerhead. Position the shower unit vertically.

Allow enough room between the ceiling and the shower to access the cover top screws.

### **IMPORTANT: Water regulations**

It is required that the showerhead be 'constrained by a fixed or sliding attachment so that it can only discharge water at a point not less than 25mm above the spill-over level of the relevant bath, shower tray or other fixed appliance'.

If the riser kit is supplied with a 'soap dish hose retainer' or bespoke 'hose retainer', it will in most cases meet this requirement. If the showerhead can still be placed within a bath, basin or shower tray within the 25mm limit, then a double check valve or similar, **MUST be fitted in the supply pipework to prevent back-flow.**

### **Pressure relief safety device**

A pressure relief device (PRD) is designed into the shower unit which complies with European standards. The PRD provides a level of appliance protection should an excessive build up of pressure occur within the shower.

**Do not operate the shower with a damaged or kinked shower hose, or a blocked showerhead which can cause the PRD to operate.**

When commissioning, the showerhead must be removed from the flexible hose. Failure to follow this procedure may also cause the PRD to operate.

Make sure the shower is positioned over a bath or shower tray because if the PRD operates, then water will eject from the bottom of the unit.

Should this happen, turn off the electricity and water supplies to the shower at the isolating switch and stop valve. Contact Customer Service for advice on replacing the PRD.

## **⚠ WARNING ⚠**

The shower **MUST NOT** be positioned where it will be subjected to freezing conditions.

**Fig.6** Diagrammatic view (not to scale)

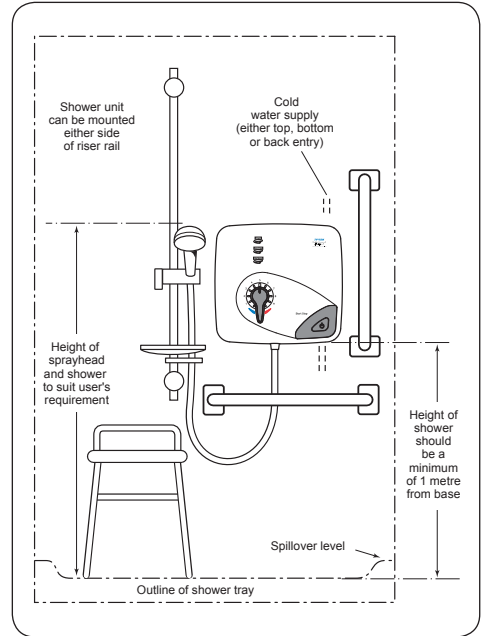

**Important:** The unit must be mounted on a flat surface which covers the full width and length of the backplate. It is important that the wall surface is flat otherwise difficulty may be encountered when fitting the cover and subsequent operation of the unit may be impaired.

## Fitting the Shower to the Wall

**Note:** The control knobs are an integral part of the cover – **DO NOT** attempt to remove them. Unscrew the top and bottom retaining screws (**fig.7**) and lift the cover from the backplate.

Entry positions for the water and electric cable are from the top, bottom, or from the back.

**Note:** Deviations from the designated entry points will invalidate product approvals.

If bottom entry has been chosen, fit the appropriate cut-out in the top of the backplate (**fig.8**).

If top entry has been chosen, fit the appropriate cut-out in the bottom of the cover (**fig.9**).

After choosing the site for the shower, to mark the four fixing holes, the position of which are shown in (**fig.7**).

Drill and plug the wall. An appropriate drill bit should be used. If the wall is brick, plasterboard or a soft building block, appropriate wall plugs and screws should be fitted.

Screw the top two fixing screw into position leaving the base of the screw head protruding 6mm out from the wall.

Hook the backplate over the top of the two screw and fit the other fixing screws into position.

**DO NOT** fully tighten the screws at this stage, as the fixing holes are elongated to allow for out of square adjustment after the plumbing connections have been completed.

**DO NOT** seal around the shower backplate or the shower cover (using silicone sealer, or similar) once the unit is fixed to the wall.

**Important PRD information: DO NOT** seal the outlet hole on the bottom left of the backplate. This is the PRD escape vent (see illustration below).

**Fig.7**

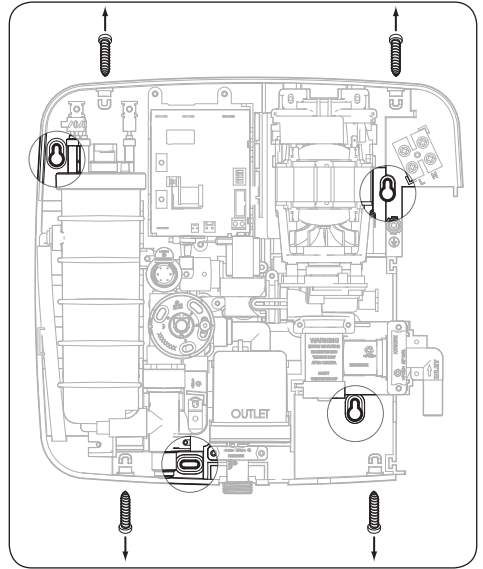

**Fig.8**

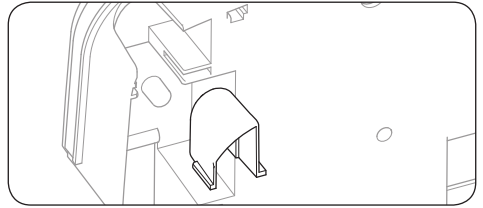

**Fig.9**

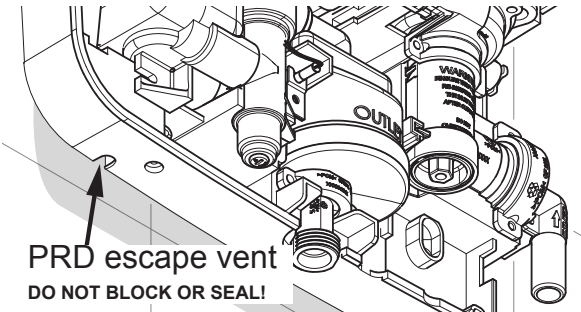
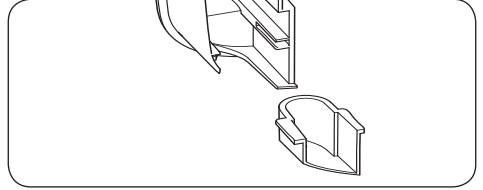

## Plumbing Connections

### Plumbing to be carried out before wiring

**DO NOT** use jointing compounds on any pipe fittings for the installation.

**DO NOT** solder fittings near the shower unit as heat can travel along pipework and damage components.

Compression fittings **Must** be used to connect to the inlet of the shower.

**Note:** An additional stop valve (complying with Water Regulations) **Must** be fitted in the water supply to the shower as an independent means of isolating the water in order to carry out maintenance or servicing. If this isolator is fitted in a loft space, the loft must have a fixed access ladder and be boarded, with appropriate lighting from the access point to the isolator.

**Important:** Before completing the connection of the water supply to the inlet of the shower, flush out the pipework to remove all swarf and system debris. This can be achieved by connecting a hose to the pipework and turning on the water supply long enough to clear the debris to waste.

### Procedure

Turn off the water supply isolating stop valve. Connect the mains water supply to the Inlet of the shower via 15mm copper, stainless steel or plastic pipe using a 15mm x 15mm compression fitting, see **Fig.10** for advice on Rear Entry fitting.

**Fig.10**

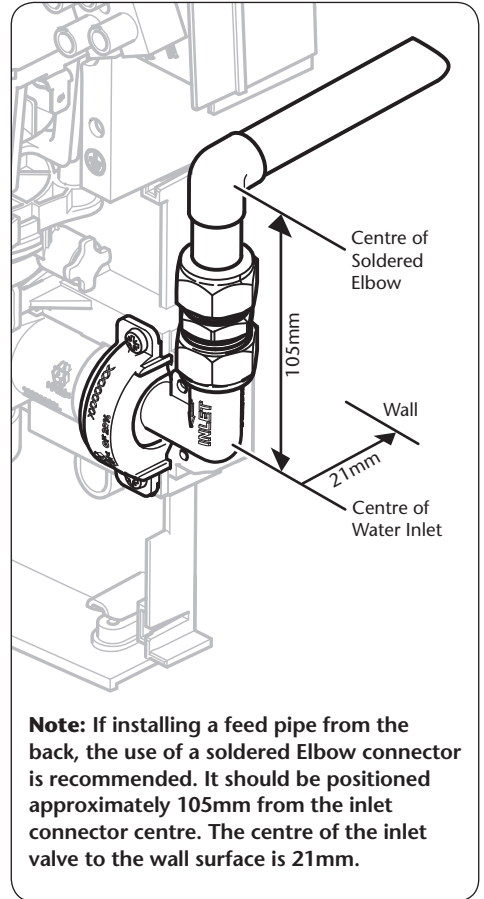

**Note:** If installing a feed pipe from the back, the use of a soldered Elbow connector is recommended. It should be positioned approximately 105mm from the inlet connector centre. The centre of the inlet valve to the wall surface is 21mm.

The Inlet fitting is designed to rotate through 180° to allow for either Top or Bottom/Rear entry fitting (**Fig.11**).

**Note:** The inlet fitting is designed to enter a compression fitting only. **DO NOT** use push fit connectors as full engagement cannot be guaranteed. **DO NOT** use excessive force when making these connections.

Make sure the backplate is square on the wall and tighten the retaining screws which hold it to the wall.

Turn on the water supply and check for leaks in the pipework connection to the shower.

**Note:** At this stage no water can flow through the unit.

**Important:** Using a suitable sealant, always seal around the incoming pipework to prevent water entering the wall.

**Important: Under No circumstances must the Inlet be rotated 90° and the pipe fitted directly. The shower has not been designed for this method of connection. See below.**

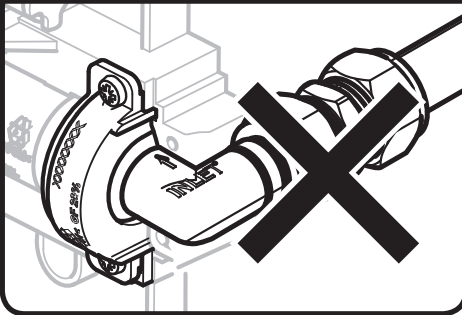

**Warning!**

The outlet of the shower acts as a vent and must not be connected to anything other than the hose and showerhead supplied.

**Fig.11**

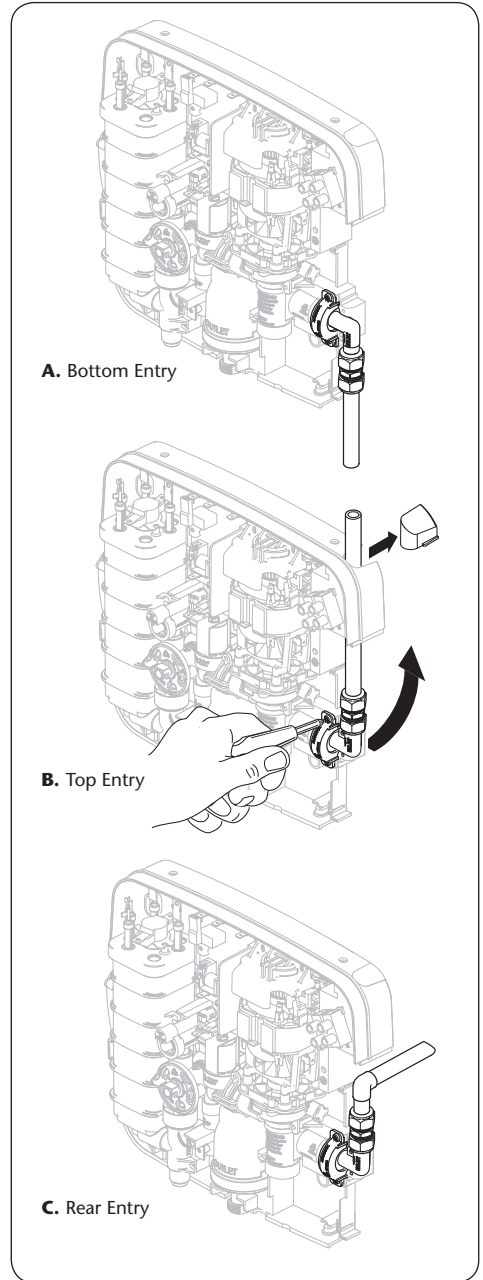

## Electrical Connections

**Switch off the electricity supply at the mains.**

**Fig.12** shows a schematic wiring diagram.

The cable entry points are shown in **Fig.1**. The cable can be surface clipped, hidden or via 20 mm conduit.

**Note:** Conduit entry can only be from rear. Route the cable into the shower unit and connect to the terminal block (**Fig.13**) as follows:

Earth cable to terminal marked 

Neutral cable to terminal marked **N**

Live cable to terminal marked **L**

**Important:** Fully tighten the terminal block screws and make sure that no cable insulation is trapped under the screws. Loose connections can result in cable overheating.

**Note:** The supply cable earth conductor must be sleeved. The outer sheath of the supply cable must be stripped back to the minimum.

The supply cable must be secured either by routing through conduit or in trunking or by embedding in the wall, in accordance with IEE regulations.

The use of connections within the unit or other points in the shower circuit, to supply power to unspecified equipment will invalidate the guarantee.

**DO NOT** switch on the electricity supply until the cover has been fitted.

**Note:** The elements on UK models are to 240V specification and will give a lower kW rating if the voltage supply is below 240V.

### Warning!

**After any servicing of the water supply, always flush out the pipework to remove any debris.**

**In these circumstances the unit should only be re-started by following the commissioning procedure on page 20.**

**Fig.12**

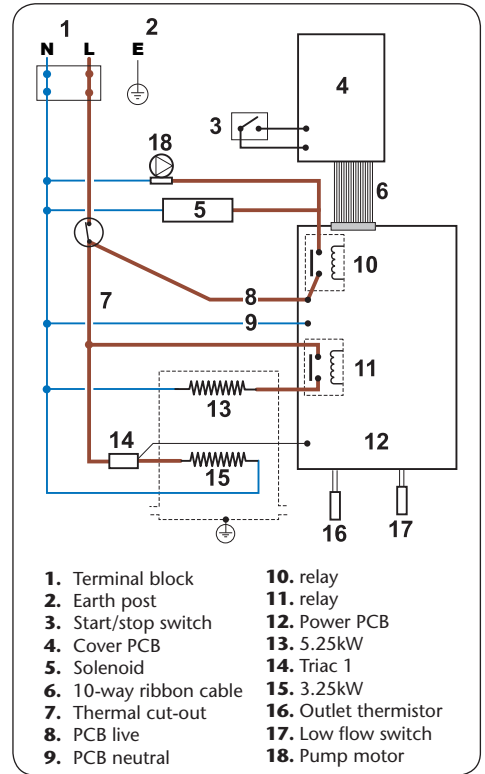

**Fig.13**

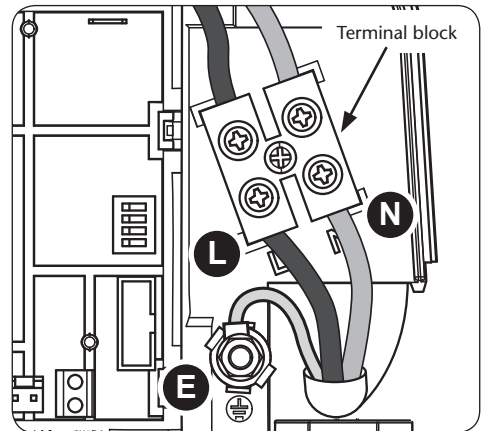

## Shower drain pumps

### Principals of operation

When the shower is turned on, an internal sensor sends a signal to the transformer to supply DC voltage to the pump.

When the shower is turned off, a signal is sent to the transformer and after a preset time delay stops the supply of DC voltage to the pump.

Please refer to the relevant Pump manufacturers installation instructions for full details of operation.

### Warning!

**The pump is a non-gravity installation. It is advised that where the property is left unattended for an extended period of time, that the water supply to the shower is shut off.**

## Connecting the Control Wire

The showers internal Control Wire electrical connector is shown in **Fig.14**.

**Note: Numbers 1 and 2 only cover connecting the outgoing wire within the shower - please refer to the relevant pump manufacturers installation instructions for pump connection and relevant IEE regulations that must be met.**

1. Connect the Control Wire from the pump to the shower via the terminal block situated at the bottom of the showers PCB.
2. The Control Wire **MUST** be routed behind **B** and out through **D**.

**The wire MUST NOT be routed near to A.**

**Fig.14** Warning! **DO NOT** route the Control wire near to (A) the Pump Motor

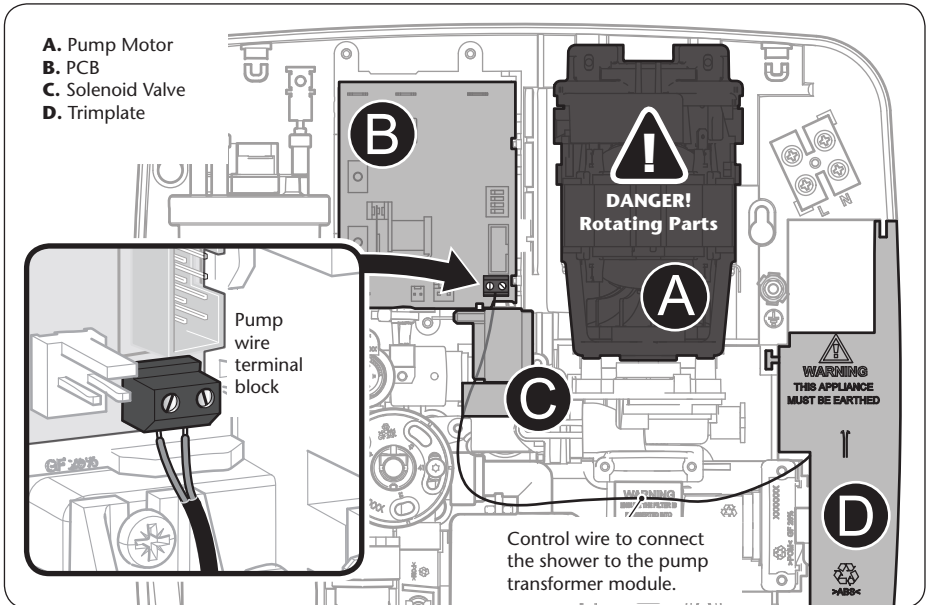

Pumps are not supplied with any products manufactured by Triton Showers (see page 19 for compatible pumps).



### PCB HANDLING & ESD PRECAUTIONS

Contact with the PCB assembly should be limited to adjustment of DIP switches and connection of the ribbon cable.

The use of an ESD wrist band is advised to reduce the risk of potential ESD damage should more extensive PCB contact be required.

## \*Compatible shower drain pumps

The following Pumps are compatible with the shower:

### **AKW Medicare.**

1. AKW Archimedes 4 - **25306-25310 (A4)**
2. AKW Archimedes 4F - **25301-25305 (A4F)**
3. AKW DigiPump 4 - **25251-25255 \*\***

Technical Helpline: **01905 823 299**

E-mail: **sales@akw-medicare.co.uk**

For AKW Pump information please visit: **www.akw-medicare.co.uk**

### **CONTOUR SHOWERS.**

1. **PRIMO-XTRA 05PP01** - Pump Only.
2. **PRIMO-XTRA 05PP01A** - With UPS-3 -22 gully to suit a shower tray.
3. **PRIMO-XTRA 05PP01B** - With USG1-WH gully to suit a wet floor former.
4. **PRIMO-XTRA 05PP01C** - With CSG1 gully for screed floors.

Technical Helpline: **01606 592 586**

E-mail: **sales@contour-showers.co.uk**

For Contour Showers Pump information please visit: **www.contour-showers.co.uk**

### **WHALE PUMPS.**

1. **SDP044T** - Tray kit.
2. **SDP054T** - Wet Floor Kit.

Technical Helpline: **0845 0694 253**

E-mail: **info@whalepumps.com**

For Whale Pump warranty information please visit: **www.whalepumps.com**

\*No endorsements are offered by Triton Showers regarding any third party products listed within this fitting book.

\*\* To be used in conjunction with supplied flow sensor on the water inlet (**NOT** to be connected to Safeguard PCB).

## Commissioning

The first operation of the shower is intended to flush out any remaining unit debris and to make sure the heater unit contains water before the elements are switched on.

- Make sure that the electricity supply to the unit and isolating switch has been turned off, then remove the front cover and disconnect the PCB cable. Also remove the right hand trimplate.
- Turn the water supply to the unit on and turn the bleed screw (**Fig.15**) approximately 3 turns out. Make sure that an absorbent cloth is in place to catch any purged water. Let the water flow, approximately 30-60 seconds is advised, until a steady stream of water with no bubbles in it flows from the bleed screw. Once this has been achieved re tighten the bleed screw.
- Refit the right hand trimplate and the cover (**Fig.16**) - **DO NOT connect the PCB cable at this time**; this will allow the unit to operate in 'commissioning mode'. This allows the pump to operate, but does not engage the heater can circuits. This is to allow the system to flush and fill with water and purge any remaining air.
- Secure the cover with a couple of the retaining screws.
- **The following operation must be carried out with the flexible hose screwed to the outlet but without the showerhead attached. Make sure the outlet of the flexible hose is directed to waste.**  
Turn the temperature control to number '1' then re-enable the power to the isolator switch. Turn on the isolator switch. The pump will operate and water will flow from the shower hose. **Note: The Start/Stop button will not be connected, the only way to exit the 'commissioning mode' is to remove power to the PCB.**
- Allow the system to run until the water flows freely without bubbles in it. Turn the temperature control knob slowly from number 1 to the temperature lock out setting and back again a few times to release any trapped air.
- **Stop the shower using the isolating switch.**
- Remove the cover, connect the PCB ribbon cable (**Fig.22**), refit the cover and secure using all of the retaining screws.

**Fig.15**

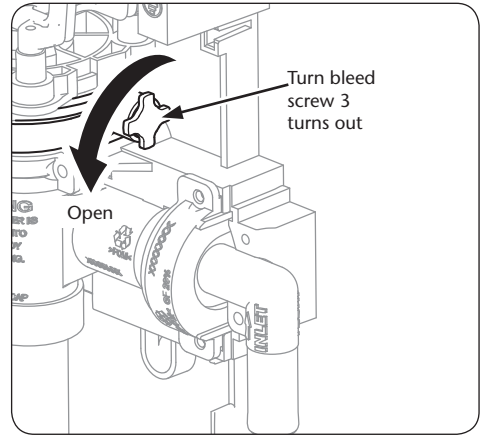

**Fig.16**

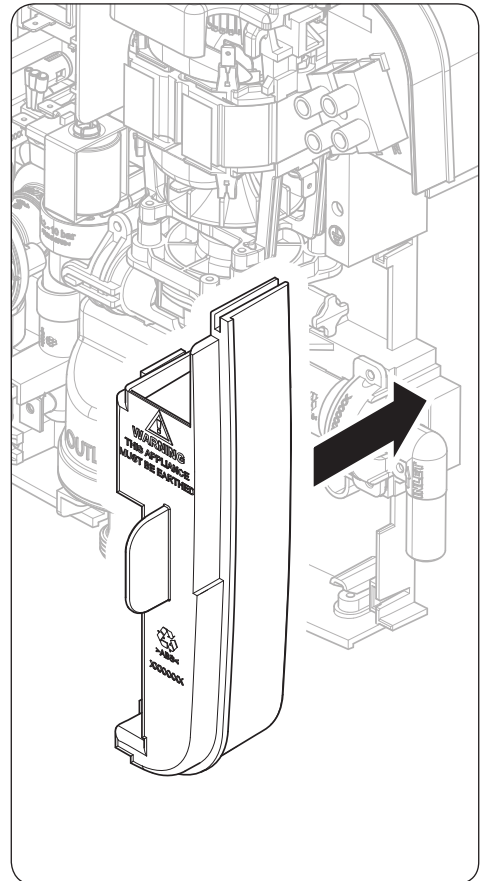

## Adjusting the Maximum temperature stop 35°C to 47°C - Standard showering

The temperature control valve has an adjustable maximum temperature stop mechanism that is supplied factory set a 47°C (fig.17).

To select a lower maximum temperature stop setting, isolate the mains electricity supply to the shower. Remove the cover and disconnect the ribbon cable from the power PCB.

(Fig.18 - 20) - remove the locking screw from the mechanism and rotate the mechanism to the preferred setting point to align with the screw fixing point. Insert the locking screw through the temperature setting label and lock in place.

Reconnect the ribbon cable, replace the cover assembly (please see page 24) and restore mains electrical power to the unit.

Fig.17

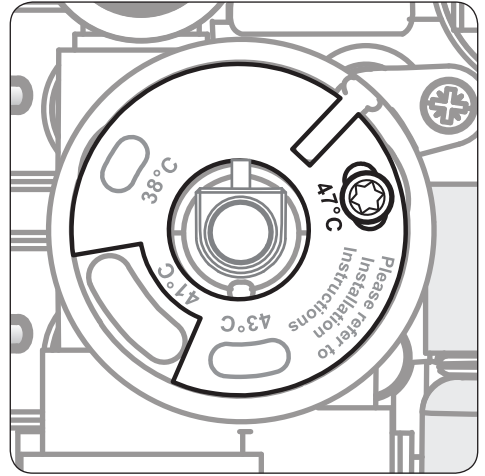
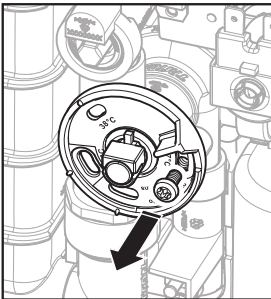
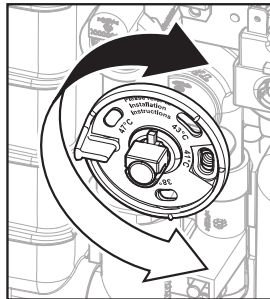

Fig.18



Remove the locking screw securing the temperature face plate.

Fig.19



Rotate the temperature face plate clockwise or anti-clockwise until the desired temperature is reached.

Fig.20

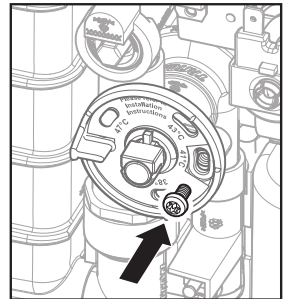

Replace the locking screw securing the temperature face plate at the new temperature.

### IMPORTANT:

Please follow the procedure outlined on page 22 when altering the maximum stop to conform with the BEAB Care (41°C) showering setting.

## BEAB Care

Fig.21

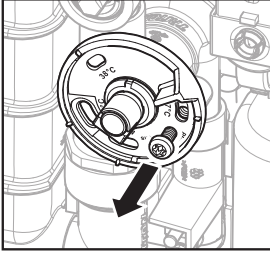

Fig.22

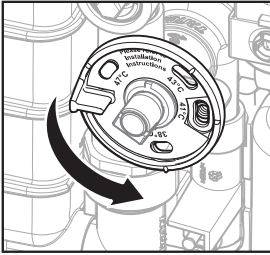

Fig.23

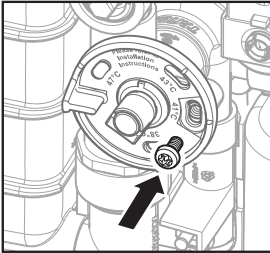
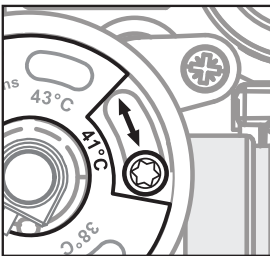

Fig.24



### IMPORTANT INFORMATION:

\*BEAB care mark specification states a **MAXIMUM** of 41°C outlet temperature.

If the shower is adjusted above the maximum 41°C the product falls outside the official BEAB care mark specification.

### Setting the temperature stop to \*41°C, BEAB Care use

Isolate the mains electricity supply to the shower.

With the cover on, rotate the temperature control fully anti-clockwise past number 1 until it stops.

Remove the cover and disconnect the ribbon cable from the power PCB.

Remove the locking screw securing the temperature face plate (**Fig.21**).

Rotate the temperature face plate to align the 41°C slot with the screw hole (**Fig.22**).

Replace the locking screw (**Fig.23**) but **DO NOT FULLY TIGHTEN THE SCREW AT THIS TIME**.

Rotate the temperature face plate fully anti-clockwise making sure that the screw is sitting at the lowest point of the slot (**Fig.24**).

Reconnect the power PCB cable and replace the cover assembly (**please see page 24**).

Restore mains electrical power to the unit.

Start the shower by pressing the Start/Stop button.

**The shower should be run for a minimum of 30 seconds to allow the water temperature from the handset to stabilise.**

Following the instructions given on **page 34 (section 1: Measuring the Shower Outlet Water Temperature)**, slowly rotate the temperature control until the water temperature is \*41°C (or below).

Switch off the shower and isolate the unit from the mains electricity supply.

Remove the cover and disconnect the ribbon cable from the power PCB.

Fully tighten the temperature face plate locking screw, making sure the face plate position does not alter.

Reconnect the ribbon cable, replace the cover assembly (**please see page 24**) and restore mains electrical power to the unit.

**Important:** When set to 41°C (BEAB Care setting) the temperature lever will sit at setting 5 (approximately) as its **maximum** position. **DO NOT FORCE THE LEVER ANY FURTHER ONCE RESISTANCE IS FELT.**

## Dip switch settings

A four way DIP switch block is mounted on the control PCB that allows the user to configure the shower to perform different functions (fig.25).

Fig.25

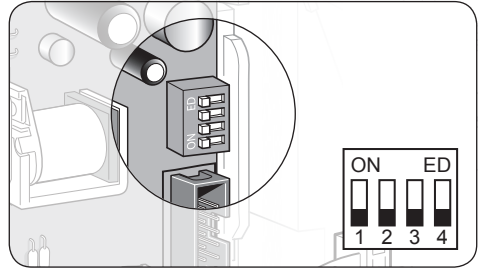

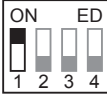
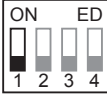
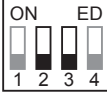
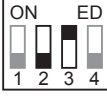
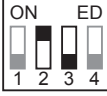
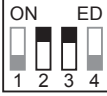
Dip Switch No.	Operation Enabled	Switch Position
DIP switch 1 <b>On</b>	Audible Feedback <b>On</b> <b>(Factory setting)</b>	 <b>On</b>
DIP switch 1 <b>Off</b>	Audible Feedback <b>Off</b>	 <b>Off</b>
DIP switch 2 <b>Off</b> DIP switch 3 <b>Off</b>	Timed Shutdown - <b>5 Mins</b>	 <b>5 Mins</b>
DIP switch 2 <b>Off</b> DIP switch 3 <b>On</b>	Timed Shutdown - <b>10 Mins</b>	 <b>10 Mins</b>
DIP switch 2 <b>On</b> DIP switch 3 <b>Off</b>	Timed Shutdown - <b>20 Mins</b> <b>(Factory setting)</b>	 <b>20 Mins</b>
DIP switch 2 <b>On</b> DIP switch 3 <b>On</b>	Timed Shutdown - <b>30 Mins</b>	 <b>30 Mins</b>
DIP switch 4	Spare	

## Fitting the Cover

Attached to the display PCB inside the cover, is a 10-way ribbon cable. The ribbon cable connector must be plugged into the socket located at the right of the power PCB situated inside the unit (**fig.26**).

**Note:** The cable connector can be fitted to the socket only one way. The ribbon cable has a coloured edge which is at the bottom when correctly fitted to the socket.

**Note:** The ribbon cable is preformed to fold flat when the cover is fitted.

**Important:** Before finally fitting the cover, the following steps must be taken:

- a. Check all plumbing connections are watertight.
- b. Check terminal block screws are fully tightened.
- c. Make sure pipe and cable entering the unit do not prevent the cover locating correctly to the backplate.
- d. Right hand trimplate is secured.

Offer the cover to the unit.

Guide into position so that the knob spindle locates correctly (minor adjustment may be necessary to align the knob and spindle). Should any difficulty arise, re check the points above.

While applying slight pressure to the cover, secure in position with the retaining screws.

Turn the electric supply back on at the isolating switch. The 'Power' indicator will light. No water will flow now until the **Start/Stop** button is pressed.

However, it is recommended that the water and electric supplies to the shower are turned off while the riser rail kit is being installed.

The flexible hose can be left attached to the shower outlet. Make sure the supplied sealing washer is fitted.

**Fig.26**

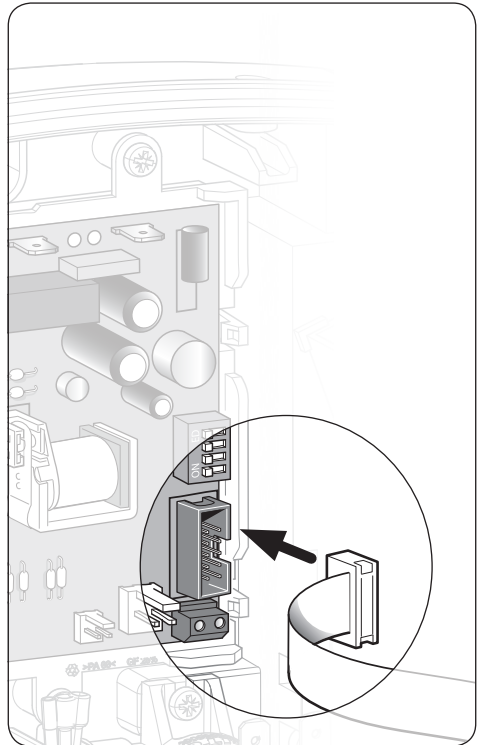

### **\*Note**

The 'Timed Shutdown Indicator' will only operate if the unit reaches one of the predetermined shut down times of: 5, 10, 20 (factory setting) or 30 minutes. To set the unit to one of these times see page 23.



### **COVER RETAINING SCREWS**

**ONLY** the **SUPPLIED SCREWS** should be used. The use of none supplied screws **WILL** invalidate product specifications & warranty.

## Operating functions (fig.27)

### Power on indicator (green)

When the electricity supply to the shower is switched on at the isolating switch, the power indicator will light up.

### Low flow indicator (red)

If a low flow condition occurs the unit will turn off the water flow immediately. It will be necessary to wait until water in the unit has reduced to a comfortable temperature, at which point the LED will extinguish. Pressing the start button will then restart the unit.

### \*Timed Shutdown indicator (yellow)

The operation of this LED denotes that a 'Timed shutdown' has been programmed into the unit. When the indicator illuminates it indicates there is 1 minute before the timed shutdown setting. The indicator will then flash for 5 seconds prior to the shower switching off, an audible beep will also commence if it has been set to do so (see commissioning section for information on how to program the unit).

### Phased shutdown

In use, every time the Start/Stop button is pressed, power is switched off to the elements. Water will continue to flow for a few seconds, flushing out any remaining hot water. This makes sure the next immediate user will not receive a slug of hot water if standing under the showerhead when starting the shower.

### Temperature Protection

During normal operation, if the flow of water through the unit is restricted, power to the elements will be reduced to maintain the shower temperature. When the flow of water through the unit returns to normal, power to the elements will be automatically restored to the setting at the time of interruption.

### Safety cut-out

The unit is fitted with an over-temperature safety device. In the event of abnormal operation which could cause unsafe temperatures within the unit, the device will disconnect the heating elements and remove power from the electronics making the shower unit inoperable.

**It will require a visit from a qualified engineer to identify the nature of the fault and replace the safety device.**

Fig.27

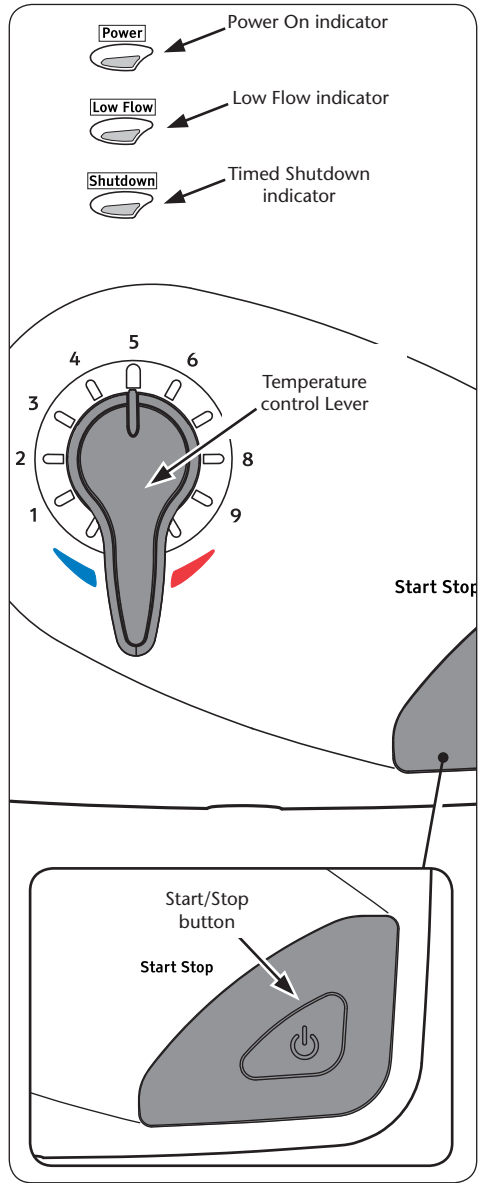

## IMPORTANT

The shower unit **MUST BE** switched off at the isolating switch when not in use. This is a safety procedure recommended for all electrical appliances.

# Instructions for installers and service engineers only

## Cleaning the filter

It is recommended that the filter is periodically cleaned in order to maintain the performance of the shower. It is essential that this operation is carried out by a competent person.

### Switch off the electricity and water supply to the shower.

The inlet filter is situated inside the water inlet fitting (**Fig.28**).

To gain access to the filter remove the cover and right hand trim plate. Unscrew the cap on the water inlet fitting.

Inspect the 'O' ring for damage when the filter is removed. Do not over tighten the filter cap on reassembly.

When cleaning the filter, **DO NOT** use a sharp object as it will cause damage. It is preferable to use an old toothbrush or similar.

Fig.28

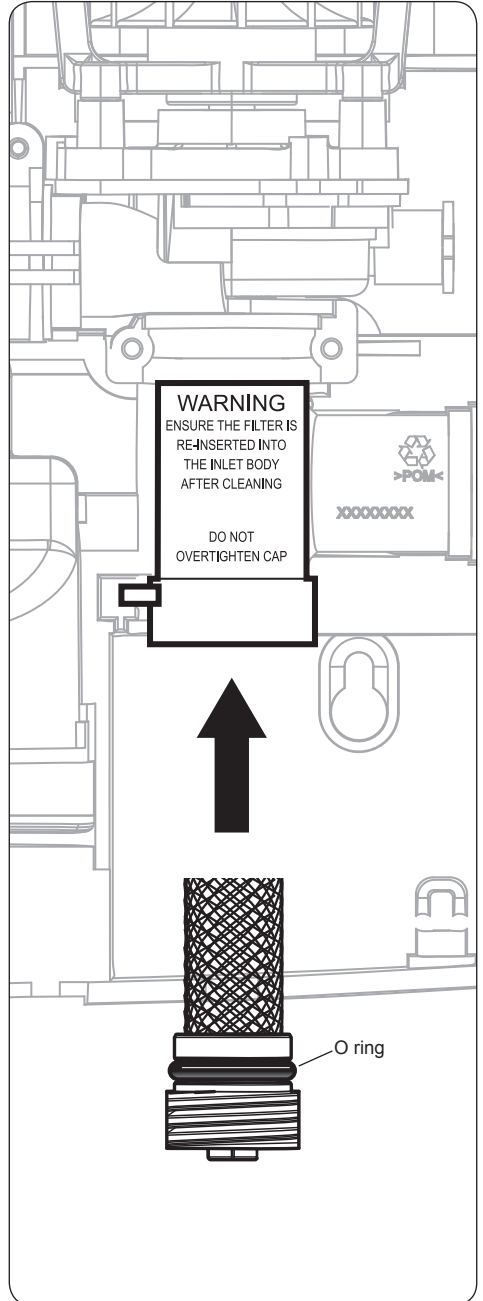

## Spare parts

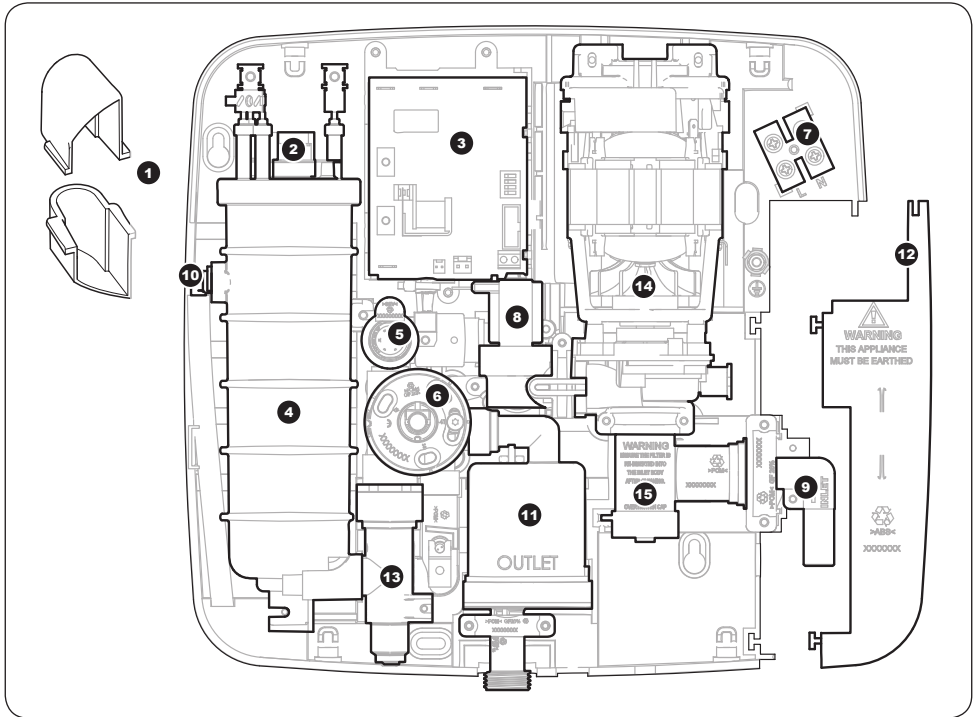

### Ref. Description

### Part No.

1.	Top and bottom pipe entry trim .....	83313430
2.	Thermal safety cut-out.....	22012020
3.	Power printed circuit board .....	7073740
4.	Can and element assembly .....	83315370 (230v)
5.	Flow switch assembly .....	S19521007
6.	Temperature control assembly.....	S19520805
7.	Terminal block and wires .....	S23410901
8.	Solenoid valve assembly .....	P23410801
9.	Water inlet assembly.....	P23411001
10.	Pressure relief device (PRD).....	82800450
11.	Shower outlet reservoir.....	P23410802
12.	Access trimplate .....	7053949
13.	Heater inlet valve assembly.....	S82100345
14.	Motor and pump assembly.....	P15211002
15.	Inlet filter assembly.....	S23410804

## Spare parts

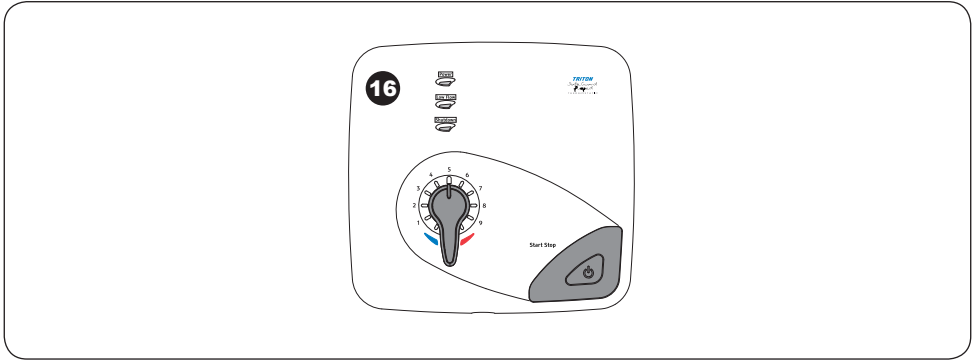

### Ref. Description

### Part No.

- 
- Solenoid outlet elbow assembly (not shown) .....P23410803
  - Heater can wire set (not shown).....8331 3440
  - Triac and wires (not shown) .....P19520903
  - Thermistor (not shown) .....22012030
- 16.** Safeguard Pumped Care front cover assembly .....S23410603  
(includes cover PCB and start/stop switch)

## Fault finding

**Important:** Switch off the electricity at the mains supply and remove the circuit fuse before attempting any fault finding inside the unit.

<b>Problem/Symptom</b>	<b>Cause</b>	<b>Action/Cure</b>
<b>1</b> Shower inoperable, no water flow.	<b>1.1</b> Interrupted power supply.	<b>1.1.1</b> Blown fuse or circuit breaker. Check supply Renew or reset fuse or circuit breaker. If it fails again, consult a qualified electrician.
	<b>1.2</b> Unit malfunction.	<b>1.2.1</b> Power cut? Check other appliances and if necessary, contact local Electricity Supply Co.
		<b>1.2.2</b> Have unit checked. Ring Customer Service.
<b>2</b> Water too hot.	<b>1.3</b> Thermal cut-out operated.	<b>1.3.1</b> The thermal cut-out safety device has operated. Have the unit checked by a suitably qualified service engineer or contact Customer Service.
	<b>2.1</b> Temperature control set incorrectly.	<b>2.1.1</b> Alter the temperature control.
	<b>2.2</b> Unit malfunction.	<b>2.2.1</b> Have the unit checked by a suitably qualified service engineer or contact Customer Service.
<b>3</b> Water too cool or cold.	<b>3.1</b> Temperature control set incorrectly.	<b>3.1.1</b> Alter the temperature control.
	<b>3.2</b> Maximum temperature stop set incorrectly.	<b>3.2.1</b> Alter the Maximum temperature stop.
	<b>3.3</b> Unit malfunction.	<b>3.3.1</b> Have the unit checked by a suitably qualified service engineer or contact Customer Service.
<b>4</b> Water will not stop flowing from unit unless switched off at isolating switch.	<b>4.1</b> Control ribbon cable is not connected to PCB.	<b>4.1.1</b> Remove cover and connect ribbon cable.
<b>5</b> Pressure relief device has operated (water ejected from PRD tube).	<b>5.1</b> Blocked showerhead.	<b>5.1.1</b> Clean sprayplate and then fit a new PRD.
	<b>5.2</b> Twisted/blocked flexible shower hose.	<b>5.2.1</b> Check for free passage through hose. Replace hose if necessary and then fit new PRD.
	<b>5.3</b> Showerhead not removed while commissioning.	<b>5.3.1</b> Fit new PRD. Commission unit with showerhead removed.

## Fault finding

<b>Problem/Symptom</b>	<b>Cause</b>	<b>Action/Cure</b>
<b>6</b> Low flow LED permanently on when start/stop bar pressed. Shower will not start.	<b>6.1</b> Low flow condition	<b>6.1.1</b> Insufficient water flow available. 1. Check showerhead is not blocked 2. Check shower hose is not restricted. 3. Check filter is not blocked. 4. Check water supply to shower is adequate
<b>7</b> Low flow LED comes on when shower is running. Shower switches off.	<b>7.1</b> Low flow condition has caused temperature sensor in the shower to operate.	<b>7.1.1</b> Shower will not start until water in the unit has cooled and LED goes off. If problem persists. 1. Check showerhead is not blocked 2. Check shower hose is not restricted. 3. Check filter is not blocked. 4. Check water supply to shower is adequate
<b>8</b> Low flow LED flashes continuously when start/stop bar pressed. Shower will not start.	<b>8.1</b> Flow switch has failed	<b>8.1.1</b> Replace flow switch assembly
<b>9</b> Low flow and shutdown LED's alternately flashing when power turned on to unit. Shower will not start.	<b>9.1</b> Start/Stop switch failed	<b>9.1.1</b> Replace cover assembly
<b>10</b> Low flow and shutdown LED'S flashing simultaneously when start/stop bar pressed. Shower will not start.	<b>10.1</b> Outlet thermistor failed	<b>10.1.1</b> Replace thermistor
<b>11</b> Low flow and shutdown LED'S permanently on when power is turned on. Shower will not start.	<b>11.1</b> Power pcb faulty	<b>11.1.1</b> Replace power pcb

Note: Identify cause of operation before fitting new PRD unit. When fitting a new PRD, follow the commissioning procedure.

It is advised all electrical maintenance/repairs to the shower should be carried out by a suitably qualified person.

In the unlikely event of unit failure other than detailed in the fault finding page, please contact Customer Service for advice.

# **In-service Testing Safeguard Pumped Care**

**Designation Code:  
-IW-S Shower**

## Commissioning

Where installed (Establishment): \_\_\_\_\_ Location of Unit: \_\_\_\_\_  
 Installed/commissioned by: \_\_\_\_\_ Signed: \_\_\_\_\_ Date: \_\_\_\_\_

Date of Commissioning	*Prior to Installation:									
	1	2	3	4	5	6	7	8	9	10
	Check unit designation matches the intended use	Check that the Maximum temperature stop is set to 41°C (See page 20)	Water supply static pressure (see page 12 - Water Requirements).	Water supply running pressure (see page 12 - Water Requirements).	Water supply temperature (Range: 5 - 20°C).	Terminal voltage (Range: 230V ± 10%).	Ambient temperature of water supply (see Note 2).	Supply voltage at appliance Terminals (see Note 2).	Maximum water temperature at shower outlet (see Note 3).	Maximum water temperature when water supply is restricted (see Note 4).
dd/mm/yy	Yes/No	Yes/No	bar	bar	°C	V	°C	V	°C	°C

**\*Prior to Installation check:**

- a) The inlet filter of the shower is free from debris.
- b) The in-line check valves or other back-flow prevention devices are in good working order.
- c) Any isolating valves on the water supplying the unit are fully opened.

Column 7: This test should be performed by measuring temperature from a gravity fed cold water tap.  
 Columns 8-10: These tests should be performed after resetting the shower to the default running setting by pressing the **'Start'** button on the shower cover.

**List of Test Equipment Used:**

Measurement:	Test equipment used (Model, make, etc)/Method used:	Identification:	Date of last calibration:
Supply water pressure			
Voltage			
Water temperature			

**Note:** All installation, commissioning and in-service testing must be undertaken by a suitably qualified engineer.



## Notes for commissioning and in-service testing

### 1. Measuring the Shower Outlet Water Temperature

With the shower running, position the showerhead horizontally and place a funnel under the water flow. Make sure that the funnel mouth collects all of the water emitted from the showerhead. Take a reading using a temperature probe in the collected water flowing from the outlet of the funnel.

Typical dimensions of a suitable funnel are:

Opening diameter: 110mm,  
Throat diameter: 15mm.

### 2. Measuring the Heated Water from Shower Outlet

After resetting the shower to the default setting (press the 'Start' button on the shower cover) measure using the method described in (1.) above.

### 3. Measurement of Heated Water from the - Shower Outlet when Restricting the - Water Supply

Progressively restrict the inlet water flow to the unit using the service valve (see page 12) until the 'Low' LED comes on (on the cover) and the shower shuts down with no water flow from the showerhead. Open the service valve slightly and restart the shower using the Stop/Start button. Record the resulting outlet water temperature using the method described in (1.) above. If this exceeds 43°C withdraw the shower from service and call Customer Service.

**Note:** The service valve should be returned to the fully open position after this test.

### 4. Measurement of Supply Voltage at Appliance Terminals

Switch off the electricity at the mains supply and remove the circuit fuse. Remove the shower cover, taking care to position it so that it does not hang by the interconnecting ribbon cable.

Replace the circuit fuse and switch on the electrical mains supply. Take the AC voltage reading across the Live and Neutral screws of the mains terminal block.

Take care NOT to touch any other internal components of the shower. Switch off the electricity at the mains supply, remove the circuit fuse and replace the cover using the screws supplied.

**Note:** This test should only be performed by a suitably qualified engineer.

### 5. When the Set Maximum Outlet Water Temperature has Changed Significantly

If the set maximum outlet water temperature has changed significantly from the previous test results (greater than  $\pm 1^{\circ}\text{C}$ ), check that:

- a. The outlet fittings (showerhead/shower hose) are free from restrictions and limescale.
- b. The inlet filter of the shower is free from debris (see page 26).
- c. In-line check valves or other back-flow prevention devices are in good working order.
- d. Any isolating valves on the water supplying the unit are fully opened.

If, after making the above checks, an acceptable outlet water temperature is not achieved withdraw the shower from service and contact Customer Service.

## Frequency of in-service testing

**Table 1**

Conditions for In-service test	Next in-service test
First in-service test.	6 to 8 weeks after commissioning.
If no significant change in water outlet temperature (greater than $\pm 1^{\circ}\text{C}$ ) between commissioning and first test.	12 months after commissioning.
On going service testing.	Annually on the anniversary date when the unit was commissioned.

# Entry Points

## Diagram Key:



**Water** Entry Points



**Cable** Entry Points

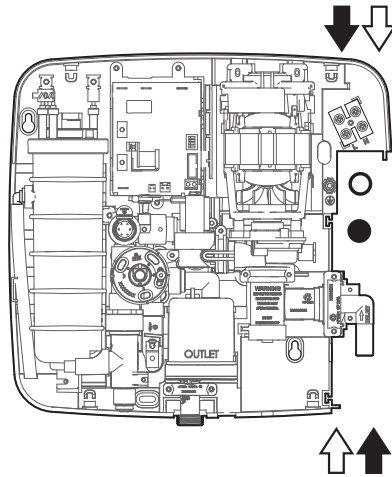

## WEEE Directive – Policy Statement

As a producer and a supplier of electric showers, Triton Showers is committed to the protection of the environment via our own environmental policy and the compliance with the **WEEE directive**.

Triton Showers is fully registered with the Environment Agency under the following schemes:

Repic: Producers take-back scheme (PTS), registration number WEE/EJ3466QV

Valpak: Distributor take-back scheme (DTS), registration number 9659

All our electric products are labelled accordingly with the crossed out wheeled bin symbol. This indicates, for disposal purposes at end of life, that these products must be taken to a recognised collection points, such as local authority sites/local recycling centres; this will be free of any charges. **Do not return to Triton Showers.**



## SERVICE POLICY

**In the event of a product fault or complaint occurring, the following procedure should be followed:**

### **DO NOT REMOVE THE PRODUCT**

1. Telephone Customer Service on **01 628 6711** or **01 628 6845** having available your details including post code, the model number and power rating of the product, together with the date of purchase and, where applicable, details of the particular fault.
2. If required, the Customer Service Advisor will arrange for a qualified engineer to call.
3. All products attended to by a Triton service engineer must be installed in full accordance with the Triton installation guide applicable to the product. Every product pack contains an installation guide, however, they can also be downloaded free at [www.tritonshowers.ie](http://www.tritonshowers.ie).
4. Our engineer will require local parking and if a permit is required, this must be available to the engineer on arrival at the call.
5. If loft access is required for isolation or to complete a repair, the loft must have a fixed access ladder and be boarded, with appropriate lighting from the access point to and around the repair area.
6. It is essential that you or an appointed representative, who must be over 18 years of age, is present for the duration of the service engineer's visit. If the product is in guarantee you must produce proof of purchase.
7. Where a call under the terms of guarantee has been booked and the failure is not product related (i.e. scaling and furring, incorrect water pressure, pressure relief device operation or electrical/plumbing installation fault) a charge will be made. A charge will also be issued if nobody is at home when the service engineer calls or adequate parking/permit is not available.
8. If the product is no longer covered by the guarantee an up-front fixed fee will be charged before the site visit.
9. Your receipt must be retained as proof of purchase. Should proof of purchase not be available on an 'in-guarantee' call, or should the service engineer find that the product is no longer under guarantee, the engineer will charge the same fixed price and will request payment prior to departing. If payment is not made on the day an administration charge will be added to the fixed charge.
10. If a debt is outstanding from a previous visit, or from any other Triton purchase, Triton reserves the right to withhold service until the debt has been settled.
11. Triton takes the health, safety and wellbeing of its employees very seriously and expects customers to treat all staff members with respect. Should any employee feel threatened or receive abuse, either verbally or physically, Triton reserves the right to withhold service.

### **Replacement Parts Policy**

In line with AMDEA guidelines, Triton retains functional spares for as long as there is a market for them and in most cases, well beyond. Due to the vast array of product types, the life cycle of products can vary and therefore so can the length of time parts can be supplied. Spare parts can be ordered via our online spare parts store or by telephoning Triton Customer Service Spares Department on **01 628 6711**. Payment should be made by credit / debit card (excluding American Express or Diners Card). Payment can also be made by pre-payment of a pro-forma invoice, by cheque or postal order.

**Telephone orders are based on information given during the call. Before contacting Triton, please verify your requirements using the Information contained in the user guide. Triton cannot accept liability for incorrect part identification.**

## TRITON STANDARD GUARANTEE

With the exception of accessories, Triton guarantee the product against all manufacturing defects for a period of **2 years** (for domestic use only) from the date of purchase, provided that it has been installed by a competent person in full accordance with the fitting instructions.

All accessories such as shower heads, hoses and riser rails carry a **1 year** parts only guarantee against manufacturing defects.

Any part found to be defective during this guarantee period we undertake to repair or replace at our option without charge, so long as it has been properly maintained and operated in accordance with the operating instructions and has not been subject to misuse or damage. This product must not be taken apart, modified or repaired except by a person authorised by Triton. This guarantee applies only to products installed within the Republic of Ireland and does not apply to products used commercially. This guarantee does not affect your statutory rights.

### **What is not covered:**

1. Breakdown due to:
  - a) use other than domestic use by the property occupants;
  - b) wilful act or neglect;
  - c) any malfunction resulting from the incorrect use or quality of electricity, gas or water or incorrect setting of controls;
  - d) failure to install in accordance with this installation guide.
2. Claims for missing parts once the product has been installed.
3. Repair costs for damage caused by foreign objects or substances.
4. Total loss of the product due to non-availability of parts.
5. Compensation for loss of use of the product or consequential loss of any kind.
6. Call out charges due to an abortive visit or where no fault has been found with the appliance.
7. The cost of repair or replacement of isolating switches, electrical cable, fuses and/or circuit breakers or any other accessories installed at the same time. Replacement of the Pressure Relief Device that only activates when the shower outlet is blocked is also excluded.
8. The cost of routine maintenance, adjustments, overhaul modifications or loss or damage arising therefrom, including the cost of repairing damage, breakdown, malfunction caused by corrosion, furring, frost or exposure to freezing conditions.
9. Call out charges where the water supply cannot be isolated, this includes consequential losses arising from unserviceable supply valves, or inaccessible product or valves located in a loft space without suitable access.

**For the latest Terms & Conditions please see:**

**[www.tritonshowers.ie](http://www.tritonshowers.ie)**

Earthridge International Ltd  
Maynooth  
Co. Kildare.

Triton Showers  
Triton Road  
Nuneaton  
Warwickshire, CV11 4NR

Triton is a division of Norcoros Group (Holdings) Limited

TRITON reserve the right to change product specification without prior notice. E&OE. © TRITON SHOWERS 2019