

Linea Zoom LED Mirror - 1000 x 500mm

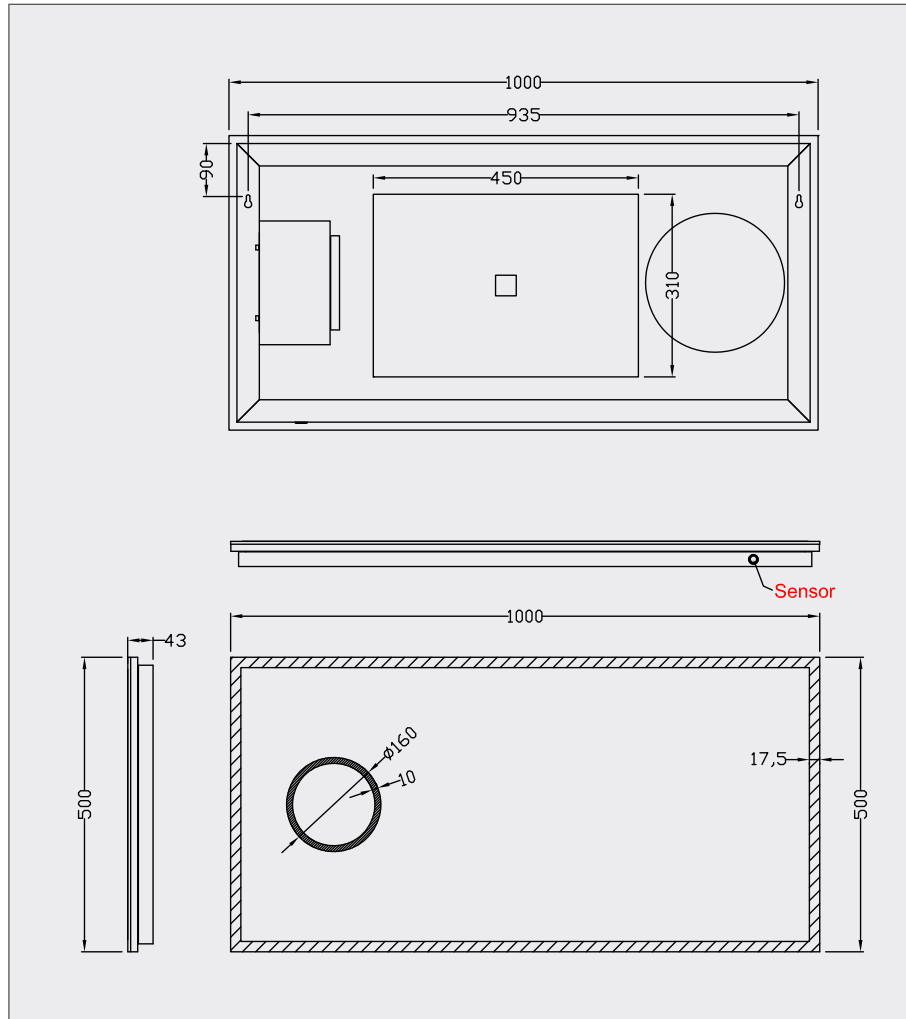

Linea Zoom LED Mirror - 1000 x 500mm

Code: 3LZ105

Features

- Energy efficient LED lighting
- Heated demister pad
- 3x Magnification in-built shaving mirror
- Infrared on/off sensor



Landscape Fitting Only

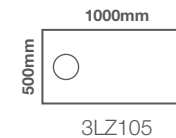

Units 3 & 4
16 Crawfordsburn Road
Newtownards
County Down BT23 4EA

Tel: +44 (0) 28 9182 8000
Fax: +44 (0) 28 9181 2888

Sales Enquiries

Email: info@aquallabrassware.com

Technical and Aftersales Support

Email: support@aquallabrassware.com



www.aquallabrassware.com

© 2018 Aqualla. All rights reserved.